

Ceramic IR Heaters & Panels



FEATURES

- * Surface temperature to 750 °C.
- * Mid-to-far wavelength infrared heat source provides uniform heat over a large area.
- * Primary emission in the 3 - 10 micron range (no visible light), which is the most efficient wavelength for heating of plastics, paper, textiles, and drying of most solvents.
- * Available with built-in type K thermocouple.
- * Available in 122 x 60 mm, 245 x 60 mm, and 122 x 122 mm sizes.
- * Available with pink surface that turns to gray when heating providing evidence of correct operation.
- * Clean, non-contaminating, heat operation. Glaze-coated ceramic body with no surface flaking or oxidation as on metal sheath elements.
- * Provides perfectly repeatable performance.
- * Easily arranged in large arrays that may be set up and controlled in zones.
- * Operating life over 5,000 hours minimizes machine downtime.
- * Iron alloy element wire provides longer life than nickel-chrome alloy wires.
- * Resistant to thermal shock. Heaters are not damaged if hit by water spray.

APPLICATIONS

Plastics:

- * Thermoforming
- * Vacuum forming
- * Curing extruded parts
- * Drying
- * Laminating

Paper:

- * Speed drying coated paper
- * Adhesive activation
- * Element Selection

Thin Film Deposition:

- * Vacuum coating

Wood/Furniture:

- * Heating bonded/painted/plastic coated components
- * Drying same components

Paint:

- * Drying lacquers/finishes
- * Baking lacquers/finishes

Electronics:

- * Preheat PCBs
- * IR reflow ovens for

Textiles:

- * Drying dyed/printed fabric
- * Curing latex coatings

Food:

- * Warming
- * Baking

Printing:

- * Ink drying

Packaging:

- * Heat shrink
- * Forming



CORPORATE

115, Jaywant Ind. Estate, Opp. Sobo Central Mall,
63, Pt. M. M. Malaviya Road, Mumbai 400 034, India
Tel: +91 22 2353 1025; Fax: +91 22 2351 7431
Mob: +91 93 2224 4540

Email: info@heatsource.in

FACTORY

Bldg No. E-8, Parasnath Complex, Village Valgaon,
Dapoda Road, Tal.Bhiwandi, Thane 421 302, India
Tel: +91 2522 645665; Mob: +91 93222 32090
Mob: +91 98207 12343

Web: www.heatsource.in



In association with ROTFIL ITALY

≡ SIZES

245 x 60 mm, CURVED

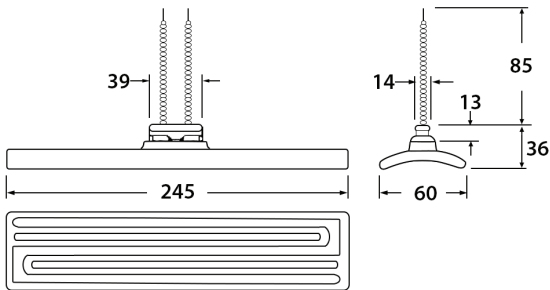

Reflector Assemblies

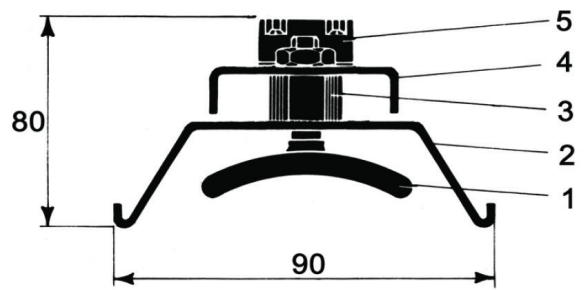

ITEMS:

- 5 - Terminal Blocks
- 4 - Supporting Frame
- 3 - Spacers
- 2 - Reflector
- 1 - Heaters

122 x 60 mm, CURVED

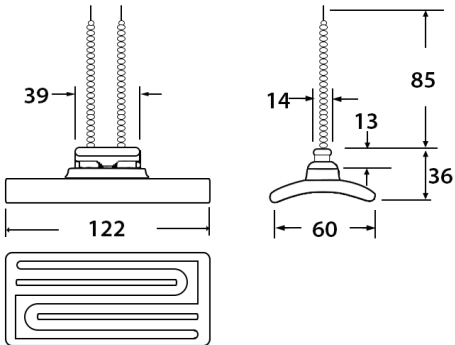

122 x 122 mm, FLAT

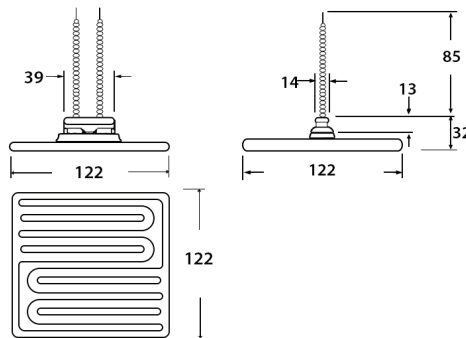

CORPORATE

115, Jaywant Ind. Estate, Opp. Sobo Central Mall,
63, Pt. M. M. Malaviya Road, Mumbai 400 034, India
Tel: +91 22 2353 1025; Fax: +91 22 2351 7431
Mob: +91 93 2224 4540

Email: info@heatsource.in

FACTORY

Bldg No. E-8, Parasnath Complex, Village Valgaon,
Dapoda Road, Tal.Bhiwandi, Thane 421 302, India
Tel: +91 2522 645665; Mob: +91 93222 32090
Mob: +91 98207 12343

Web: www.heatsource.in